

**Petter Marine Diesel Engines
TYPE AC1WM**

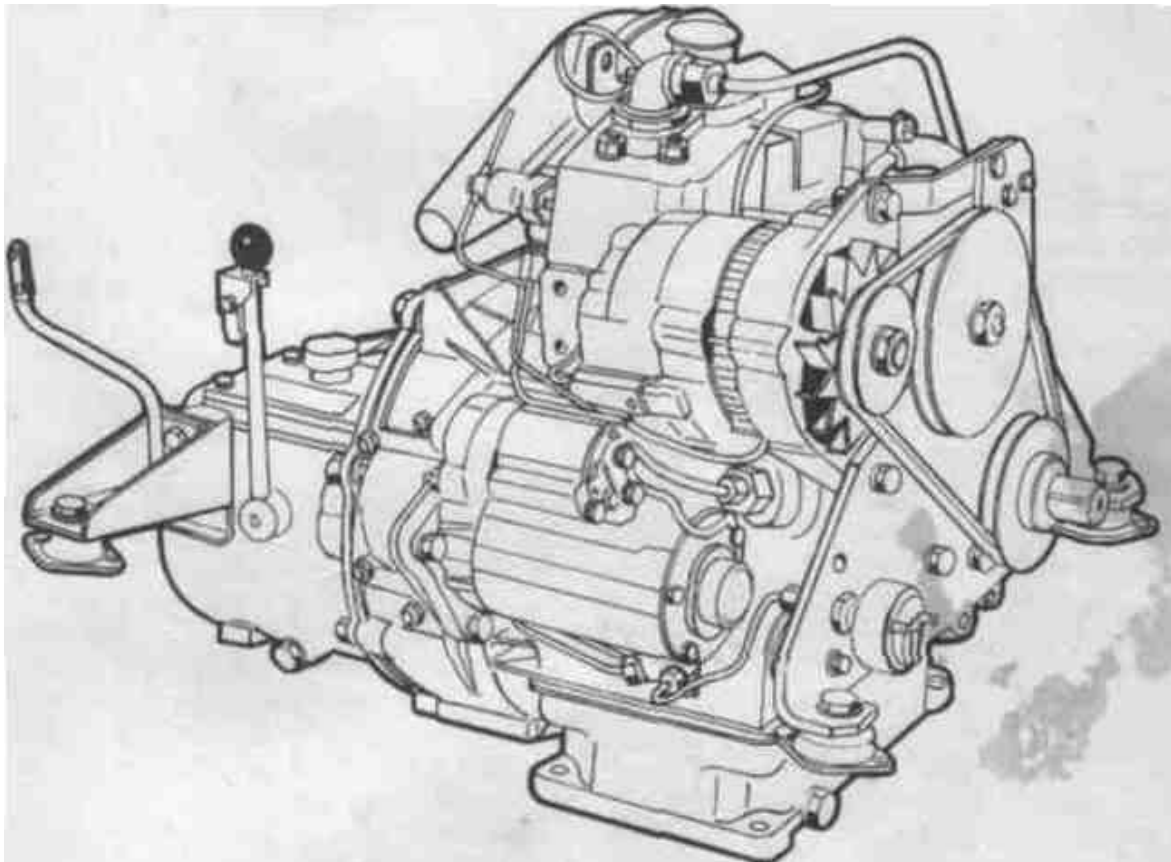

**The information given in this book relates to the
marinisation of the Petter AC1W diesel engine.
For all other engine details see the latest edition of
the AB1 W -AC1 W Operators Handbook.**

NOTE

As propeller selection is primarily related to boat rather than engine characteristics, Potters cannot be held responsible for incorrect propeller sizing. A device should be sought from a propeller specialist or a Naval Architect on specific installations.

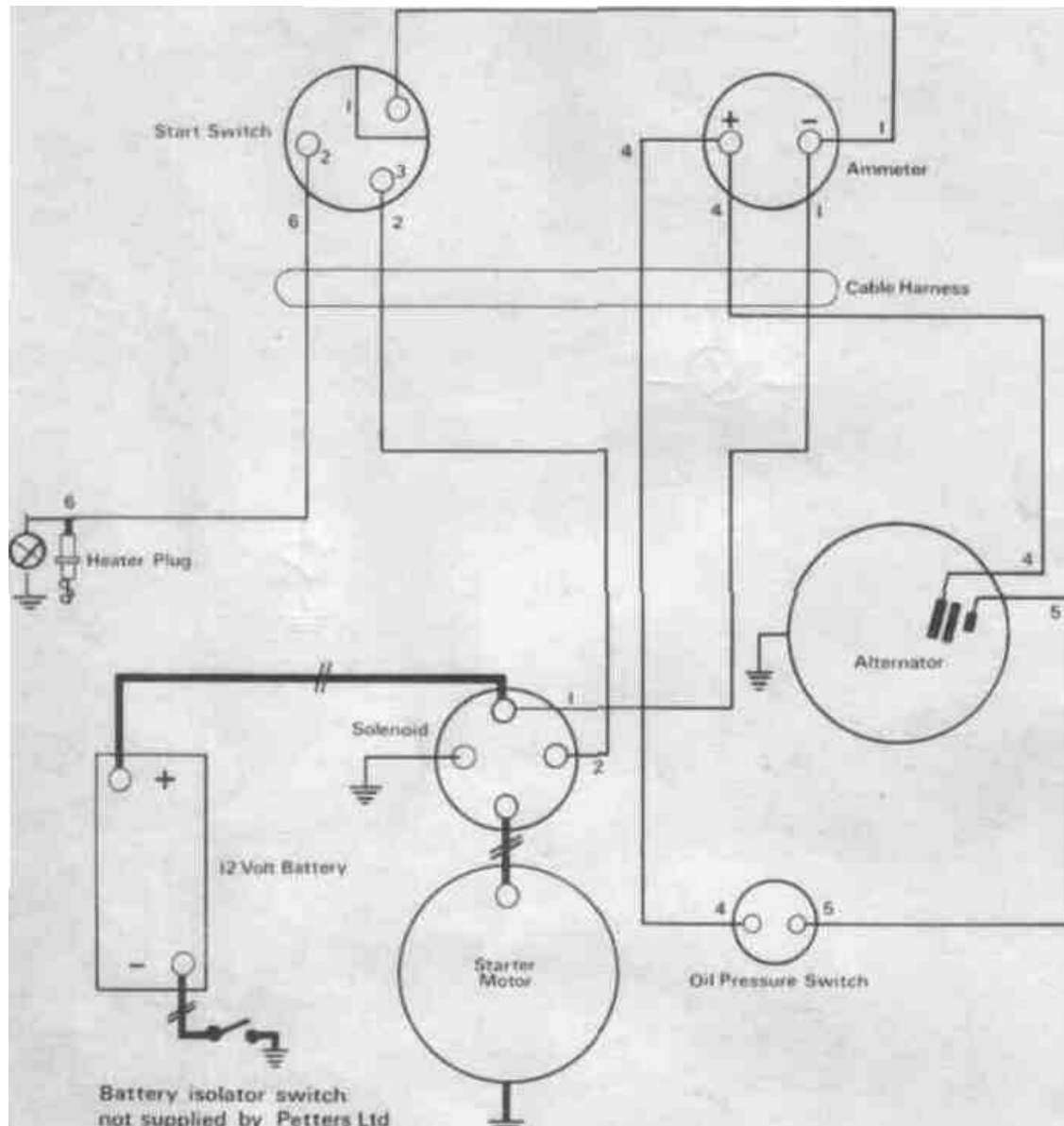

---//--- 50mm² Cable All

General Information

1. Technical Data

Gearbox ratios (forward and reverse)	2:1
Gearbox oil capacity	0.85 litres (1 1/2 pints)
Gearbox oil type	As engine oil (see Approved Lubricants)
Measurements	mm (in)
Angle of Operation Max.	22° Thwartships

Installation Angle (Fig. I)

2. The maximum angle of installation including bow lift is 22°. with a standard engine lubricating oil dipstick the maximum angle is 12° including bowlift. (or angles over 12° a steep angle dipstick is required or the standard dipstick should be modified as follows:

The maximum mark will be 13.5mm (0.53 in) above the existing mark and the dipstick should be cut off 20mm (0.73 in) below the existing mark, this will be the minimum mark.

The original high mark should be ground or filed out to prevent errors. the reverse gear dipstick will not require to be modified.

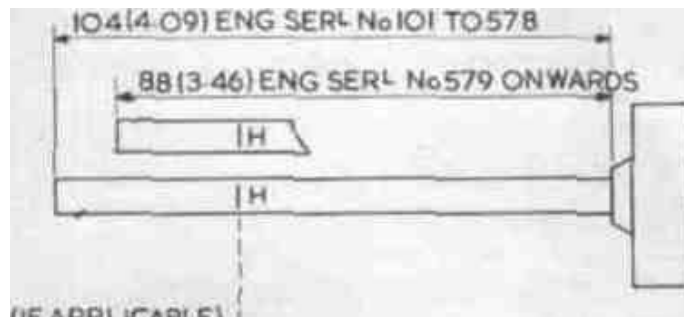

Standaard DIP stick
0° – 12° inc bow lift

3. Rotation

When going ahead, the propeller shaft rotation is anti-clockwise when looking forward towards the gearbox and will require a left-handed propeller.

4. Trouble location

- (a) For general overheating of engine compartment and lack of power, check that air inlet and outlet openings are not blocked.
- (b) If overheating occurs owing to cooling system failure:
 - (i) Check that inlet water sea cock has been opened.
 - (ii) Ensure inlet water strainer and suction pipe to pump are not blocked.
 - (iii) Examine water pump impeller and seals for damage and leakage.
- (c) If engine lacks power or suffers from speed surging:
 - (i) Check that propeller is not fouled.
 - (ii) Check if clutch in gearbox is slipping. Drive can be maintained by reducing engine speed but examination and adjustment should be carried out as soon as possible.
- (d) Heavy vibration could be caused by loose holding down bolts or coupling misalignment.
- (e) See engine handbook (or location of faulty engine performance).

5. Sterngear lubrication

Ensure the propeller shaft bearing is kept well lubricated and the grease cup is topped up when necessary with Castrol LM, Mobilgrease MP or equivalent

6. Important DON'TS

DON'T run the alternator without having a battery connected otherwise a surge may be caused, possibly damaging the regulator in the alternator.

- (a) DON'T reverse the polarity of the battery, as irreparable damage to the alternator will ensue.
- (b) DON'T allow the battery to become discharged.
- (c) DON'T engage or disengage forward or reverse gear without first reducing engine speed, except in an emergency.
- (d) DON'T run the water pump for more than 30 seconds whilst dry, otherwise the impeller will be damaged.

Installation

7. Mounting bearers

- (a) The engine mounting bearers must be of rigid construction and neither deflect or twist when subjected to the weight of the engine and gearbox or their operation.

It is strongly recommended that when the engine bearers are of bare wood or glassed-in-wood, that the engine be installed on longitudinal bearers in order that the resilient mounts are not distorted. The bearers should be bolted down with studs and anchor plates or round trunnion nuts.

When the engine is mounted on to wood bearers without longitudinal bearers, which is not recommended, it is advisable to fit pressure pads between the mounting flange of the resilient mount and the wood bearers to avoid impress of the feet into the

- (b) When the engine and gearbox are installed the gearbox output shaft must line up exactly with the propeller shaft.
To allow adequate adjustment and clearance the bearers should be 334mm (13.12in) between bearers. 381mm (15.0in) centres and parallel to the propeller shaft and 6.5-8.0mm (0.25-0.31 in) above it, if engine bearers are fitted.
If the engine bearers are dispensed with the boat bearers should be 46.5-48mm (1.83-1.88in) above the propeller shaft. The dimensions in both cases allow for shimming to obtain correct alignment.
- (c) To enable the gearbox and propeller shaft half couplings to be brought together for alignment, the propeller shaft must have at least 38mm (1.50in) of forward movement from its running position and be able to rotate.
- (d) Only good quality holding down bolts or studs may be used for installing the engine and gearbox. Setscrews, coachbolts. etc., must not be used.

8. Housings

- (a) If the engine is to be totally enclosed it is important that provision is made to enable sufficient cool air for combustion and general cooling to enter, and for hot air to escape. Hot air must not re-circulate to the inlet otherwise overheating and a reduction in power will result.
- (b) Provision must also be made for routine maintenance to be carried out. including filling and draining the engine sump and gearbox, removal and fitting fuel and oil filters, and air cleaner maintenance

- (b) To ensure correct alignment proceed as follows:
- (i) With the propeller shaft in its normal running position, locate the engine and gearbox on the mounting bearers, without bolting down, so that the half couplings are 38mm (1.5in) apart with the flexible centre coupling removed.
 - (ii) Screw the two aligning pins into the gearbox half coupling and offer up the propeller shaft to check whether the pins enter squarely into the propeller shaft coupling recesses and the coupling faces are parallel. This should be carried out at 90° intervals of rotation with the couplings horizontal and vertical.
 - (iii) Packing pieces or shims may have to be inserted under the engine and gearbox supports to achieve correct alignment. Check that the coupling faces are parallel to within 0.05mm (0.002m) in any angular position.

NOTE. If packing pieces or shims are inserted under the engine bearers, they must be progressively shimmed under the holding down bolts to prevent distortion of the engine bearers.

Careful attention to the above points ensuring that the engine is correctly in line and that the resilient mounts are not forced out of alignment or distorted, will reduce vibration and heavy wear on the coupling and mounts. It is an error to assume that because an engine is resilient mounted it can be mounted on any uneven surface and that the rubber mounts will take care of all evils.

- (iv) After bolting down recheck the alignment, replace the



GEAR IN NEUTRAL

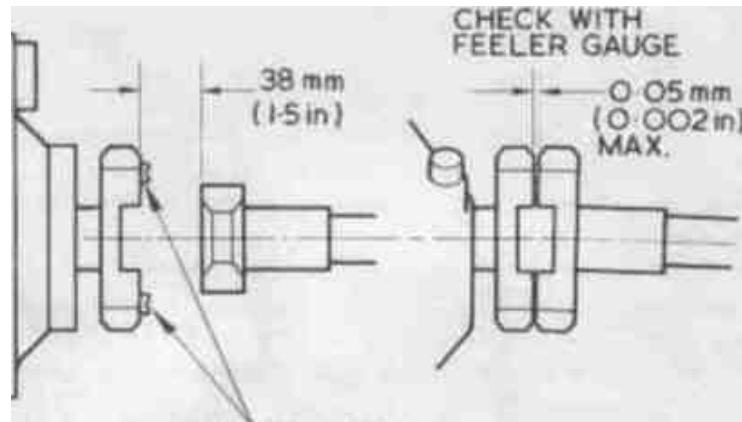

ALIGNING PINS

Fig. 2

10. Exhaust (Fig. 3)

- (a) It is important that the correct sizes and lengths of exhaust pipe are used and recommendations are given in the engine handbook. The engine exhaust port is provided with an adaptor to suit a 38mm (1.5in) bore pipe.
- (b) It is recommended that the exhaust outlet is positioned above the waterline and under no circumstances may it be fitted at a depth greater than 152mm (6in).
- (c) The exhaust system should be as short as possible with a minimum of bends, otherwise a serious reduction in power will result.

- (f) Where cooling water is injected into the exhaust system the water must enter the system 152mm (6in) before the rubber connection.
- (g) If exhaust hose is used it is important that the cooling water flow is not interrupted, otherwise overheating will occur, introducing a fire risk
- (h) To ensure that water trapped in the exhaust system does not freeze in cold weather, a drain tap must be fitted on the lowest position in the pipe run.

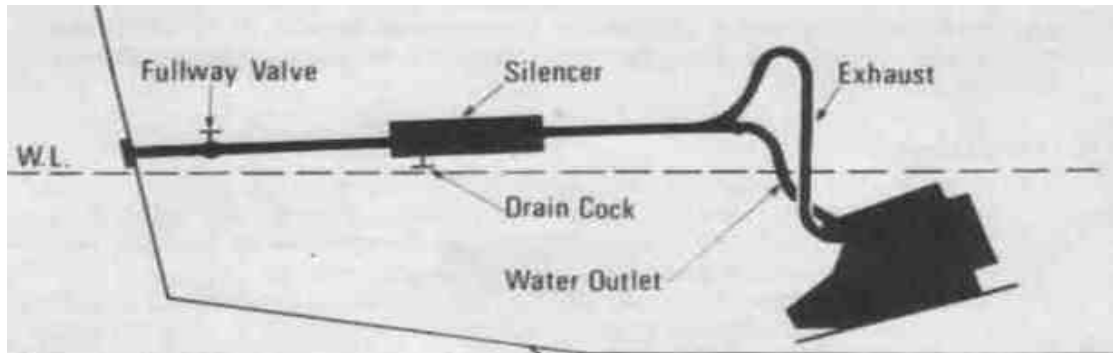

Engine Below waterline (Wet Exhaust)

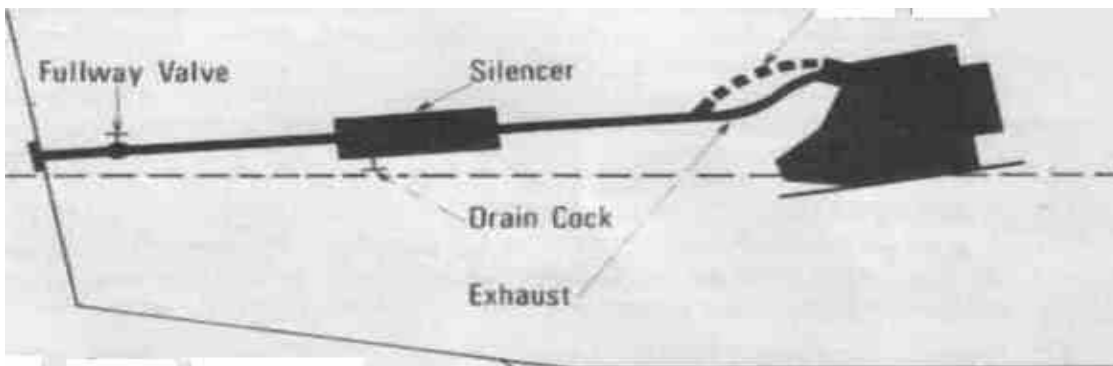

Engine above waterline (Wet or dry Exhaust)



11. Cooling

- (a) A corrosion inhibitor is included in the cooling system but it is important that brass or copper pipes and fittings are kept to a minimum. Under no circumstances must these pipes or fittings come into contact with the aluminium parts of the engine.
- (b) Water inlet and outlet hose connectors are provided on the engine and it is recommended that 9.5mm (3/8 in) bore hose is used to pipe the cooling water. This hose should be of a type that will not collapse under suction and should be kept short and free from tight bends.
- (c) A sea cock and strainer, with an inboard connection to suit a 9.5mm (3/8 in) bore hose should be connected to the pump inlet and should be positioned as close to the engine as possible with the inlet skin fitting as far below the water line as possible.
- (d) On installations without a water injected exhaust system the water outlet skin fitting should be positioned above, but as near the water line as possible.
- (e) Provision should be made for draining the whole cooling system and it is advisable to carry this out before allowing the engine to stand idle in cold weather.

12. Fuel system

A tank of adequate capacity must be installed. The engine incorporates an automatic self bleed system which requires both a supply and a spill/vent pipe. which must be connected to the top of the tank.

13. Earth connections

14. Cathodic protection

Water cooled engines are protected by a zinc insert in the water inlet fitting. To prevent corrosion of metal fittings, propeller, etc., below the water line it is recommended that a sacrificial anode is fitted to the hull. and expert advice sought on the location, size, etc.

15. Connections

All pipes, cables and controls must be flexibly connected to the unit to allow for slight movement of the unit on the anti-vibration mountings.

Operation

16. To prepare a new or overhauled engine for starting:

- (a) Fill the engine sump and gearbox with the correct quantity and grade of lubricating oil. and with the reverse gear in neutral and the engine decompressed crank the engine fifteen times to help the initial circulation of oil.
- (b) Fill the fuel tank and bleed the fuel system as described in the engine handbook.
- (c) Check that the cooling system is in order.

17. To Start

- (a) Ensure the engine sump and gearbox are topped up to the high level mark on the dipstick. With a new or overhauled engine check the engine oil level again after a few minutes running as

18. To stop

- (a) Make sure the reverse gear is in neutral and run the engine on light load a short time before stopping.
- (b) Move the STOP/RUN lever to the vertical position or pull stop control when fitted and hold until the engine stops. Then return to run position ready for re-starting.
- (c) DO NOT stop the engine with the decompressor lever.

Maintenance

19. Running maintenance

- (a) Check the lubricating oil level in the engine sump each day before use.
- (b) Check that the inlet water strainer is not blocked and the cooling system is in order each day before use.
- (c) Check the lubricating oil level in the gearbox each week and top up if necessary.
- (d) Drain the lubricating oil from the engine sump every 250 hours and gearbox every 500 hours, or both once a year whichever is sooner.
- (e) Carry out engine maintenance as described in the engine handbook at the periods recommended.
- (f) Check the flexible propeller shaft coupling and anti-vibration mountings for tightness and oil/fuel contamination at regular intervals.

- (d) Remove the cam screw and cam (D) cleaning off any sealing compound and remove the wear plate (E).
- (e) Using a hooked wire remove the seal (F) and 'O' ring (G).
- (f) Prise out the outer bearing seal (H) and remove the circlip (J).
- (g) Remove the shaft and bearing assembly (K) by applying pressure at the impeller end. Care should be taken not to damage the impeller driving slot. Careful heating of the outside of the pump body will assist in the shaft and bearing removal.
- (h) Prise out the inner bearing seal (L) and remove the water thrower (M).
- (i) Clean and examine all parts and renew where necessary.

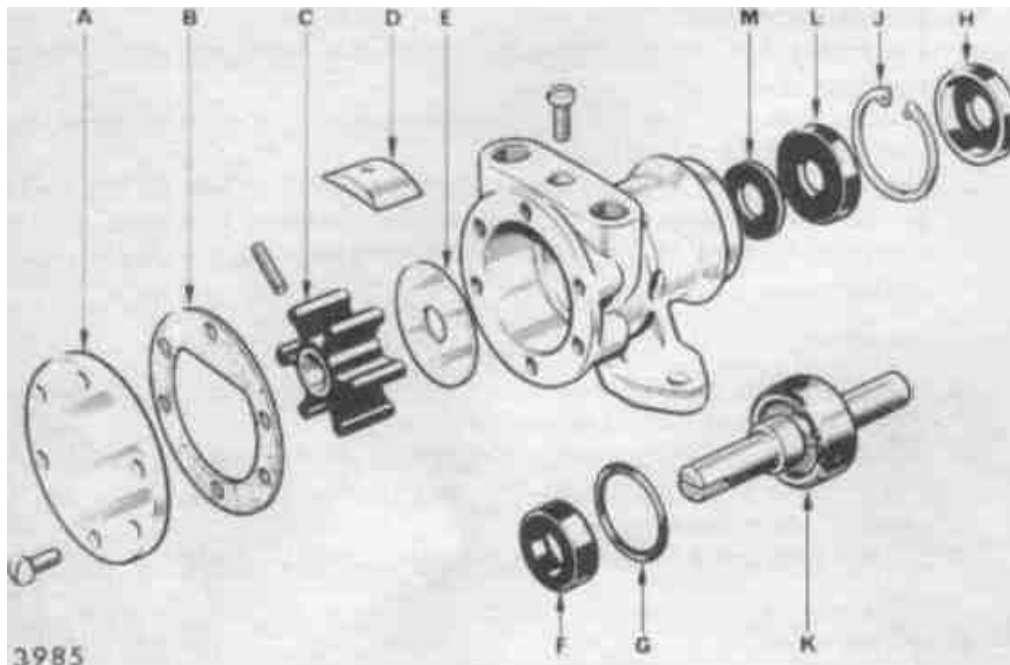

Fig. 4

- (d) Lubricate the outer bearing seal (H) with grease and press into position until flush with the pump body.
- (e) Replace the 'O' ring and seal (P) after lubricating with grease, taking care not to damage the oil seal lip. The seal should be positioned with the lip facing the impeller.
- (f) Insert the wear plate (E) with the spigot facing the impeller and in line with the cam screw.
- (g) Before replacing the cam (D), smear the top surface with sealing compound. Make sure the groove on the inner edge of the cam is located on the spigot of the wear plate. Sealing compound should also be applied to the end of the cam screw.
- (h) Replace the impeller (C) using a twisting motion until the impeller drive screw engages with the slot in the shaft.
- (i) Fit the cover plate (A) and joint (B) making sure the joint fully covers the cam. Ensure that the correct joint is used as an incorrect thickness will affect the pump performance.
- (j) Refit the water pump on the mounting plate.
- (k) Replace the water pump pulley and belt. Before tightening the pulley locking screw ensure that the pulley is in line with the other pulleys and the locking screw will seat flat on the pump shaft.
- (l) After water pump removal the belt tension will have to be adjusted (see 'Electrical system').
- (m) Replace the inlet and outlet water pipes. The pump inlet is on the right hand side looking at the pulley.

Gearbox maintenance (Fig. 5 & 6)

(a) To adjust clutch

If after extended use clutch slip occurs, indicated by the engine surging under full load, then drive may be maintained by reducing engine speed, but clutch adjustment should be carried out as soon as possible. Proceed as follows:

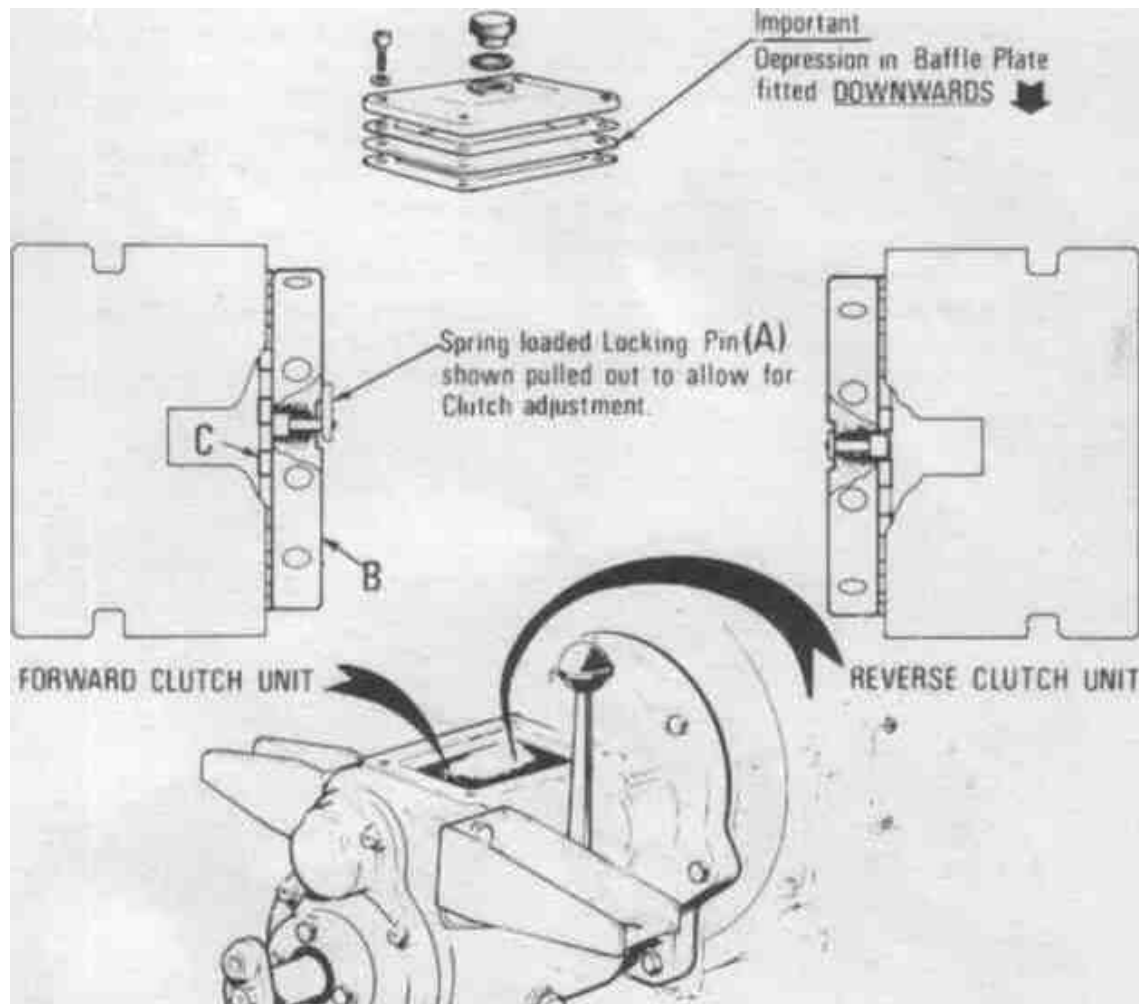

- (iii) Remove the top cover, baffle and joints from the gearbox housing and with the gear lever in the neutral position, pull out and twist the spring loaded locking pin (A) situated on the clutch unit adjusting ring (B).
 - (iv) Turn the adjusting ring approximately 3mm (1/8 in) in the direction required to increase pressure on the clutch plates and release the locking pin. Continue turning the adjusting ring until the pin engages with the next slot in the locking plate (C). There are 21 slots in the locking plate.
 - (v) After each adjustment check the force required to move the gear lever from neutral to the forward or reverse position and back to neutral. This can be checked with a spring balance attached just below the gear lever knob.
 - (vi) The force required will normally be 11.3-13.6kgf (25-30 lbf) with the engine stopped, but must not exceed 15.9kgf (35 lbf).
 - (vii) After completing adjustment and checking of both clutch units. check the gearbox oil level and replace the top cover, baffle and joints. Ensure the baffle plate with the side marked top *is* uppermost, i.e. with the depression downwards.
- (b) To remove engine and gearbox
- (i) Support the engine and gearbox from movement.
 - (ii) Disconnect and remove the output and propeller shaft flexible centre coupling.
 - (iii) Ensure that the sea cock is closed, and disconnect all pipes, control cables and wiring, etc.
 - (iv) Remove the bolts securing the engine and gearbox to the bearers.

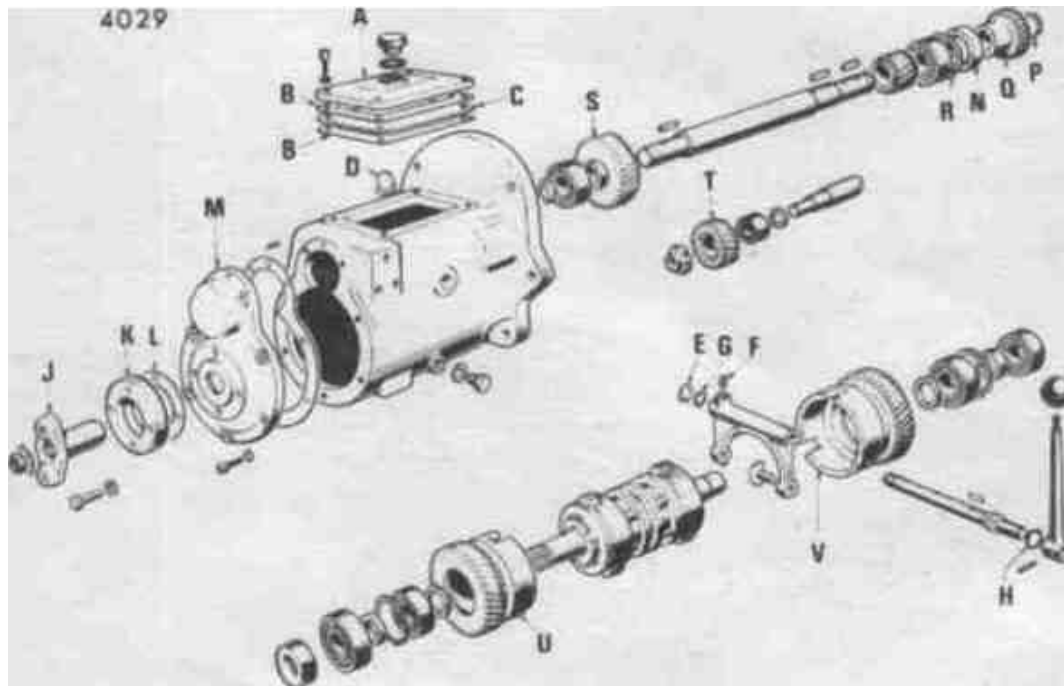

Fig. 6

- (v) With gear lever in neutral, remove the circlip (E) on the gear lever shaft, remove the gear lever shaft locking screw (F) located in the yoke. and remove the gear lever and shaft together with the oil seals (G and H). The shaft is keyed to the yoke.
- (vi) Remove the nut and tabwasher securing the gearbox coupling (J) and pull off the coupling. The coupling is splined to the shaft.
- (vii) Remove the main shaft bearing cover (K) and joint (L).
- (viii) Remove the screws securing the end cover (M), and loosely replace the coupling and nut

removal does become necessary proceed as in (xii), (xiii) and (xiv).

- (xii) Remove the circlip (P) securing the input coupling (Q) and remove the coupling. The coupling is keyed to the shaft.
- (xiii) Remove the oil seal (N) and circlip (R).
- (xiv) Press out the driving shaft together with the bearings and gears towards the flywheel end. The gear (S) at the output end must be removed before the driving shaft is clear of the casing. This gear is keyed to the shaft.
- (xv) Remove the idler gear (T) by pressing out the shaft towards the flywheel end. Care must be taken as the idler gear and distance piece will be pressed off the shaft inside the gearbox as the shaft is removed.

(d) Gearbox maintenance

- (i) Thoroughly clean all parts in paraffin or clean fuel, but do not allow the oil seals to soak.
- (ii) Allow the clutch unit to drain before replacing.
- (iii) Examine the bearings, oil seals and Joints and renew if they show signs of wear or damage.

(e) To re-assemble gearbox

- (i) Generally reverse the instructions for dismantling.
- (ii) When replacing the clutch bells ensure that the spacers are correctly fitted, and that the bell with the larger gear is fitted at the splined end of the shaft.
- (iii) When replacing the idler gear ensure the spacer is correctly fitted, i.e. with the chamfered end facing the flywheel. The shaft must be positioned so that the shoulder is in line with

- (v) Before running the engine, alignment **MUST** be carried out as described under Installation.
- (vi) Reconnect all pipes, controls and wiring, etc., ensuring the correct polarity of the battery is observed.
- (vii) Carry out the instructions under 'Prepare to Start'.

23. Electrical system

- (a) It is most **IMPORTANT** that the alternator is **NOT** run in an open circuit condition or with the polarity reversed. **NEVER** run the engine with the battery disconnected and **ALWAYS** ensure that it is connected with negative earth.
- (b) Always disconnect the socket from the alternator before carrying out any arc welding in the boat.
NOTE: Contacts in moulded socket are always live when the battery is connected, even when the engine is stopped.
- (c) The belt tension should be checked carefully. A slack belt overheats and causes low alternator output. A tight belt overloads the alternator bearings and leads to early belt and alternator bearing failure. As it depends solely on operating conditions, it is not possible to lay down any hard and fast rule as to how frequently adjustments should be made. Belt slackness should not be more than 10mm (3/8 in). To adjust belt tension, loosen the alternator pivots and adjusting strap. Make sure the pivots and strap are tightened after adjustment.
- (d) Alternators are sealed units and require no attention nor should they be dismantled in any way. However, if any defects arise they should be returned to Fetters Ltd. or their agents

25. Laying up of vessel

Engines remaining idle for more than a month may corrode and, as serious damage may result, it is recommended that they be preserved as follows:

- (a) Carry out a 1000-hour service.
- (b) Drain the sump and gearbox, flush out with flushing oil and refill with the appropriate grade of Shell Lubricating oil which will provide internal protection. (Alternatively a lubricating oil with preservative properties will be recommended by a local distributor.)
- (c) Drain the fuel tank and filter and refill the tank with sufficient Shell Fusus oil or Calibration Fluid C and run the engine on light load for five minutes without running dry. Bleed and prime the fuel system and run the engine for the required time. Close the fuel tap if fitted. The fuel system is now adequately protected against moisture.
- (d) Close the inlet water sea cock. Drain and flush out the cooling system including the water pump and hoses. It is recommended that the water pump impeller is removed and stored in a sealed jar of water.
- (e) If a prolonged lay up of the vessel is envisaged the injector should be removed and a small quantity of preservative oil applied to the cylinder and piston while cranking the engine. Replace the injector, fitting a new washer if applicable.
- (f) Remove the air inlet and exhaust manifolds, and with the inlet and exhaust valves closed, i.e. engine on compression, pour a small quantity of preservative oil into the ports to protect the valve seats. Replace the manifolds, seal the air intake and exhaust outlet

26. Preparing vessel for use after lay up

- (a) Check the engine and gearbox for corrosion and damage.
- (b) Remove the seals from the inlet and exhaust ports.
- (c) Drain the fuel tank, engine sump and gearbox if contamination is suspected.
- (d) Check and clean or renew all filters as necessary.
- (e) Remove the fuel injector. Turn the engine by means of the starting handle and check freedom of all moving parts; engage forward and reverse gear while still turning the starting handle. Refit the fuel injector.
- (f) Check the battery and refit ensuring the correct polarity is observed.
- (g) Check all nuts and bolts for tightness.
- (h) Check and lubricate all remote controls.
- (i) Check and lubricate the sterngear.
- (j) Replace the water pump impeller, if necessary, and check the cooling system is in order.
- (k) Carry out the instructions given under "To prepare to start a new or overhauled engine" in the engine handbook.
- (l) Check the Zinc Sacrificial Plug which is located in the water inlet union in the cylinder block and renew the Zinc sleeve if necessary.

Ref. No.	Description	Quantity
**WAC1	Flywheel and Gear Ring	1
**AAL1a	Starting Handle Assembly	1
	Consisting of:	
	AAL2 Plunger - Starting Handle	1
	AAL3 Spring - Starting Handle Plunger	1
	774125 Pin Starting Handle Plunger	1
	784009 Circlip - Starting Handle	1
WAB3	Cover - Rocker Box	1
**WAE5a	Pipe - Injector Leak-off	1
NAK6	Pulley - Water Pump	1
**ACL9	Starter Motor	1
**ACL10	Bracket - Starter Motor	1
MALI 9	Alternator.....	1
MAL20	Strap - Alternator Adjusting	1
**ACE21a	Pipe - Fuel (Flexible) (Filter to Pump)	1
**ACE21a	Pipe - (Flexible) (Fuel Feed Pump to Filter)...	1
NAL29	Pulley - Alternator	1
NAL30a	Belt - Alternator Driving	1
MJF31	Silencer-Exhaust	1
NAF31 a	Silencer - Exhaust (Water Injected)	1
**NAE32	Pipe - Fuel (Fuel Feed Pump Inlet)	1
BAE52	Clip - Fuel Pipes.....	5
NA056	Lever - Speed Control	1
AAK57	Tube - Suction (Oil Drain Pump)	1

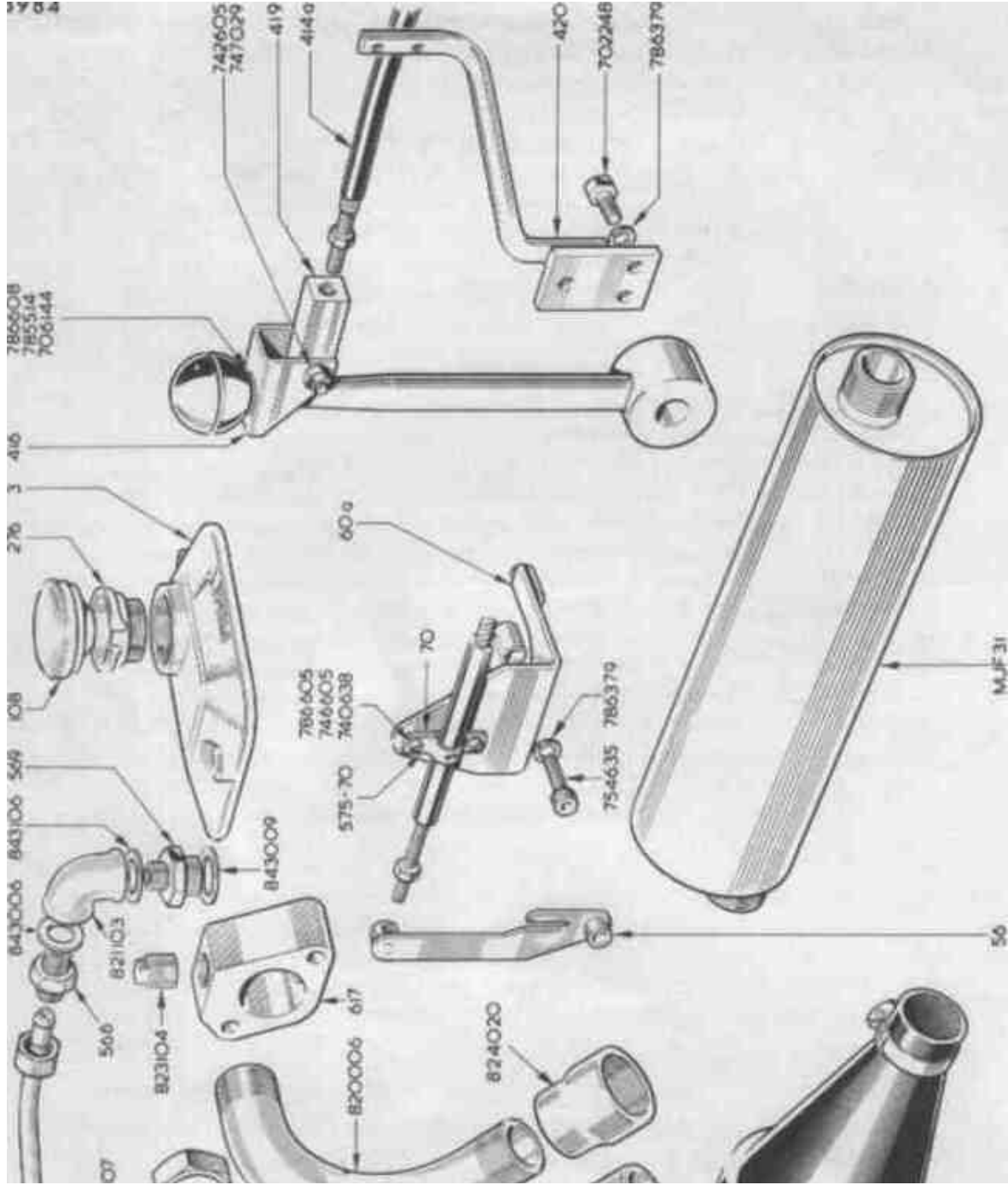

Ref. No.	Description	Quantity
**NAD60	Bracket - Speed Control	1
NAD60a	Bracket - Speed Control Cable (Remote Control).	1
NAM67a	Gearbox (for details see separate list).....	1
**BAE69	Banjo - Fuel Pump	2
NAD70	Plate - Cable Clamp	1
MAM83a	Coupling (Engine)	1
**AAK101	Pump - Oil Drain	1
NAL101a	Pulley - Camshaft Extension Shah	1
BAB108	Cap - Oil Filler	1
AAK108	Union - Oil Drain Pump	1
NAL139b	Bracket - Alternator Mounting	1
WAK170	Nut - Union (Water Pump)	1
NAM188a	Bracket - Gearbox Mounting	2
WAK189a	Pump - Water (for details see separate list)	2
**NAK199	Hose - Water (supplied loose)	1
WAK199b	Pipe - Hose Connector	2
**AAE220	Washer - (Fuel Injection Pump)	1
BAB276	Collar - Oil Filler	1
**ACE346	Washer - Vent Screw (Fuel Injection Pump)....	1
**NAM413	Single Lever - Speed and Reverse Gear Control .	1
NAA402b	Support - Engine and Gearbox Mounting	2
NAM414a	Cable - Remote Control 3m (10ft)	1
NAM415a	Cable - Remote Control 3.5m (11.5ft)	1
NAM416	Bracket - Gear Lever (Remote Control).....	1
**ACF419	Bush - Heater Plug Adaptor	2

List continues on page 29

4030

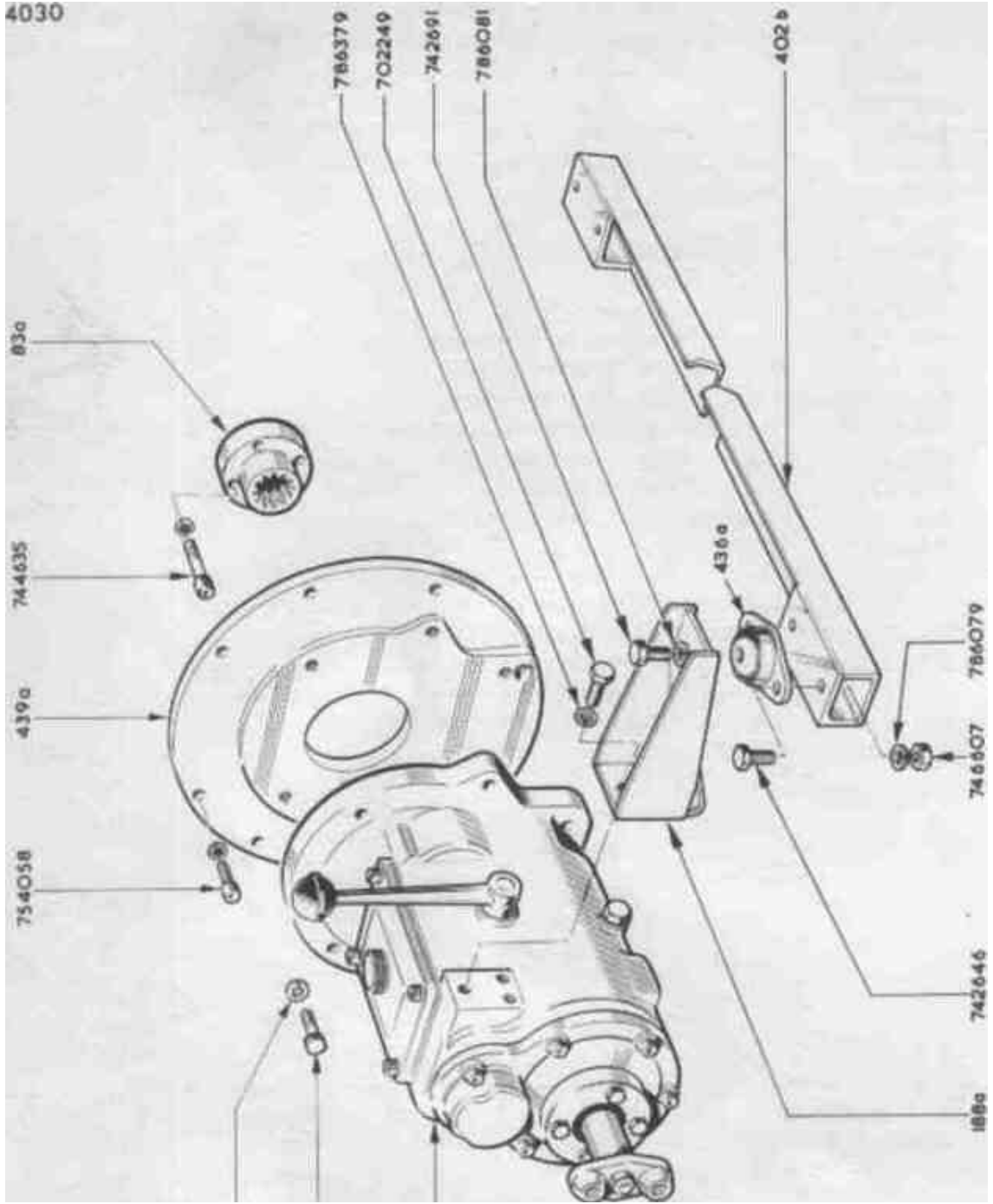

RefNo.	Description	Quantity
NAM419	Link - Control Rod (Remote Control)	1
NAM420	Bracket Control Rod Link	1
NAM436a	Mounting - Flexible	4
NAM439a	Plate - Adaptor (Gearbox to Bellhousing)	1
NAL471	Pipe - Pressure Switch	1
NAL498	Spacer - Camshaft Extension Shaft Pulley	1
WAL528	Switch Pressure.....	1
NAF563	Bend - Exhaust (Water Injected)	1
NA0564	Rod - Overload Stop	1
NAF564a	Nipple - Exhaust Hose	1
WAF565a	Pipe - Outlet (Cylinder Head to Water Injected Exhaust Bend)	1
WAF566	Union - Pipe (Water Injected Exhaust)	2
WAF569	Union - Reducing (Water Injected Exhaust)	1
NAD575	Clamp - Cable (Remote Control)	2
WAF617	Adaptor - Heater Plug (Inlet Manifold).....	1
•WAF618	Heater Plug	1

**Denotes that the part is similarly illustrated in the engine handbook, e.g. prefix letters AAL would be shown on Plate L.

*Denotes that the part is not illustrated. Stud lengths quoted are overall lengths.

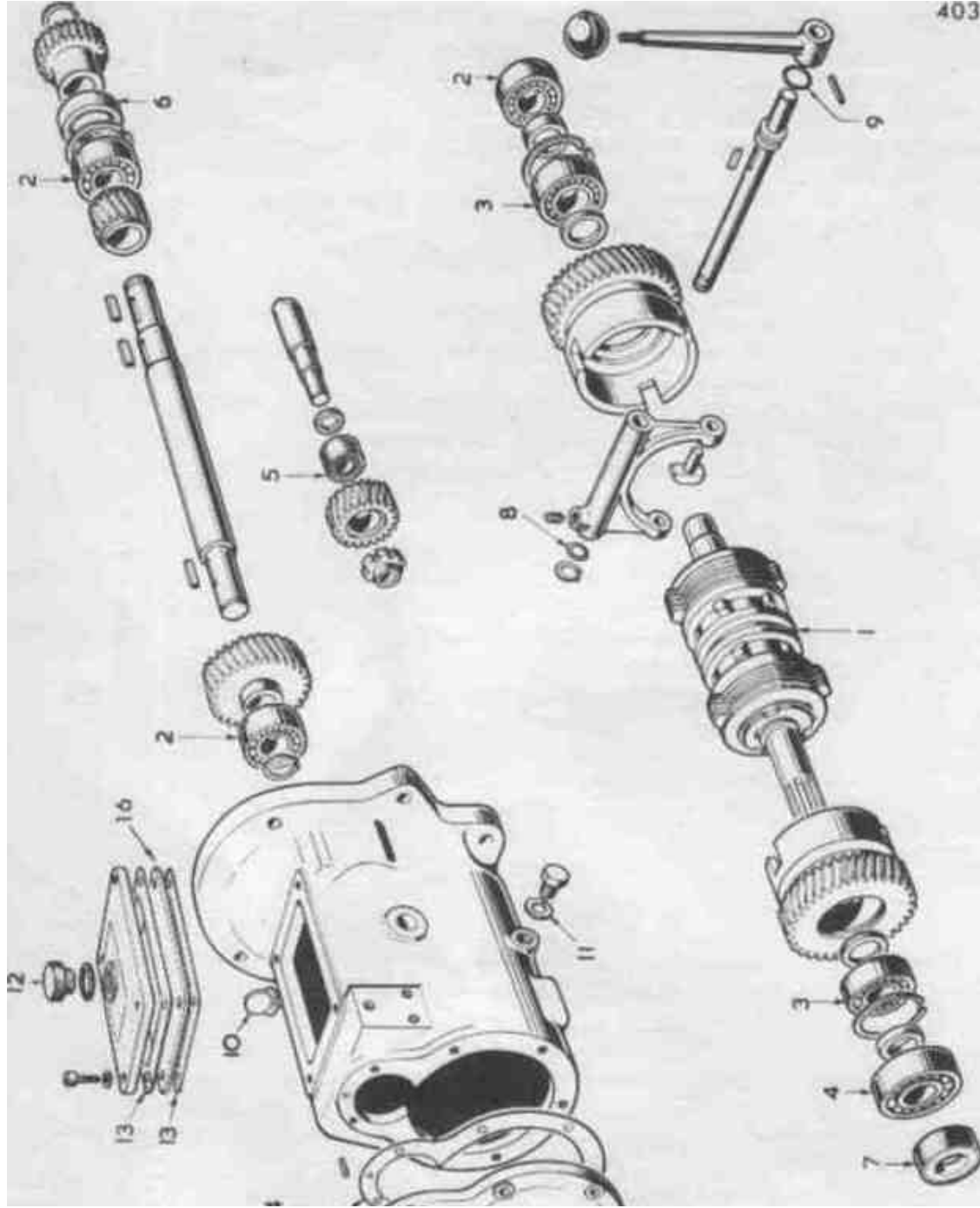

GEARBOX

Ref. No. NAM67a

When ordering spare parts for Gearbox give reference number for complete assembly (i.e. NAM67a) and then add suffix of pan required in accordance with the following list. e.g. Clutch - quote Ref. No. NAM67a/395642.

- 1 395642 Clutch
- 2 92329 Bearing - Ball
- 3 395633 Bearing - Ball
- 4 395634 Bearing - Ball
- 5 395635 Bearing - Roller
- 6 395636 Oil Seal - Driving Shaft
- 7 395637 Oil Seal - Main Shah
- 8 395638 Oil Seal - Operating Lever Shaft
- 9 395639 Oil Seal - Operating Lever Shaft
- 10 395640 Dipstick
- 11 395645 Joint Washer - Drain Plug
- 12 395641 Cap - Oil Filler
- 13 395643 Joint - Top Cover
- 14 395644 Joint - End Cover
- 15 392203 Joint - Mainshaft Bearing Cover
- 16 347729 Baffle

COMMON DETAIL PARTS

Ref. No.	Description
702248	Screw - Hex Head. M8x20 (Plated)
705245	Bolt - Hex Head. M8x35 (Plated)
706144	Lockout, M8 (Phosphated)
710611	Screw - Cheese Head, 2BA x 1 in (Plated)
727102	Nut. 5/16 in BSF (Self-locking) (Phosphated)
740638	Screw - Pan Head. 10-32 UNF x 1/2 in (Plated)
742605	Screw- Hex Head. 10-32 UNF x 1 in (Plated)
742624	Screw - Hex Head. 1/4 UNF x 5/8 in (Plated)
742627	Screw- Hex Head. 1/4 UNF x 1 in (Plated)
742648	Screw - Hex Head. 5/16 in UNF X 7/8 in (Plated)
742649	Screw- Hex Head. 5/16 in UNF x 1 in (Plated)
742651	Screw- Hex Head. 5/16 in UNF x 1 1/4 in (Plated)
742653	Screw - Hex Head. 5/16 in UNF x 1 1/2 in (Plated)
742691	Screw - Hex Head. 7/16 in UNF x 3/4 in (Plated)
744201	Grubscrew - Socket Head, 1/4 in UNF x 1/2 in (Cup Point)
744278	Grubscrew - Socket Head. 10-32 UNF x 3/8 in (Cup Point)
744635	Capscrew - Socket Head, 5/16 in UNF x 1 3/4 in (Plated)
746605	Nut, 10-32 UNF (Self-locking) (Plated)
746606	Nut. 1/4 in UNF (Self-locking) (Plated)
747029	Nut. 10-32 UNF (Self-locking) (Plated)
752625	Screw - Hex Head. 1/4 in UNC x 3/4 in (Plated)
752649	Screw - Hex Head. 5/16 in UNC x 1 in (Plated)
754058	Capscrew - Socket Head. 3/8 in UNC x 1 in
756606	Nut, 1/4 in UNC (Plated)
762638	Stud. 5/16 in UNF/UNC x 2 1/4 in (Plated)
762651	Stud. 5/16 in UNF/UNC x 4 1/4 in (Plated)
783001	Clip - Worm Drive, 3/8 in-1/2 in

786081 Spring Washer - Single Coil, 7/16 in (Rectangular Section)
(Plated)

786305 Spring Washer - Single Coil, 8mm (Rectangular Section)

786379 Spring Washer - Single Coil, 8mm (Rectangular Section)
(Plated)

786605 Washer - Shakeproof, 3/16 in (Internal Teeth) (Plated)

786607 Washer - Shakeproof, 5/16 in (Internal Teeth) (Plated)

786608 Washer - Shakeproof, 3/8 in (Internal Teeth) (Plated)

787069 Grommet, 5/16 in x 1/4 in x 3/16 in Hole

790180 Key - Parallel, 1/4 in x 1/4 in x 7/8 in (Round end)

820006 Pipe-90° Bend

821103 Elbow - 90°x 3/8 in (Female)

823104 Plug - Square Head, 1/2 in BSP

824017 Socket - Reducing, 1 1/4 in x 1 in BSP (Steel)

824020 Socket - Reducing, 1 1/2 in x 1 in BSP (Steel)

825001 Socket, 1/2 in BSP (Steel)

833025 Union (Pipe fitting one end only)

833103 Union - Reducing, 1/4 in x 1/8 in BSP (Brass)

833109 Union - Reducing, 3/8 in x 1/4 in BSP (Brass)

835107 Lockout, 1 in BSP

843006 Joint Washer, 5/8 in (Fibre)

843009 Joint Washer, 1 in (Fibre)

843104 Joint Washer, 3/8 in (Copper)

843105 Joint Washer, 1/2 in (Copper)

843106 Joint Washer, 5/8 in (Copper)